



EN 10204:2004



PARRILLA VASCA JOSPER PVJ JOSPER BASQUE GRILL PVJ

PVJ-76-3-3-MB

En el proceso de fabricación de la Parrilla Vasca usamos las mejores aleaciones de acero de alta tecnología creado por y para Josper, así como el diseño más avanzado en la construcción de parrillas tradicionales. Nuestra Parrilla Vasca ha sido diseñada con un aislamiento térmico óptimo y una reductora resistente a altas temperaturas que garantiza un movimiento suave y continuo en todo momento.

In the manufacturing process of the Basque Grill we use the best high technology steel alloys created by and for Josper, as well as the most advanced design in the construction of traditional grills. Our Basque Grill has been designed with an optimum thermal insulation and high-temperature resistant elements wich guarantee an smooth and continuous movement of the grill.



PVJ-76-3-3-MB

Superficie de braseado Braising area	760 x 600 mm (x3) 30 x 23 5/8 in (x3)
Recorrido de la parrilla Grill stroke	290 mm 11 1/2 in
Tiempo de encendido Fire up time	20 min aprox. 20 min average
Consumo diario de carbón Charcoal daily consumption	36 a 40 kg 24.2 to 26.4 lb
Temperatura de braseado Broiling temperature	250 °C 482 °F
Potencia térmica nominal Nominal heat output	6 kW 8 hp
Capacidad de extracción Exhaust rate	5500 m ³ /h 3237 cfm
Peso neto Net weight	-- kg -- lb

ACCESORIOS INCLUIDOS INCLUDED ACCESSORIES

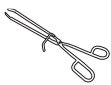

Pinzas Josper / Ref. [0423](#)
Josper tongs / Ref. [0423](#)

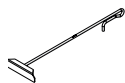

Atizador / Ref. [0401INOX](#)
Poker / Ref. [0401INOX](#)

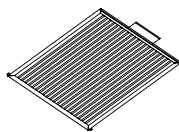

Parrilla inox / Ref. [250197](#)
Inox grill rack / Ref. [250197](#)

* Todos los productos Josper funcionan exclusivamente con carbón vegetal.
All Josper products work exclusively with charcoal.

MEDIDAS PARRILLA GRILL RACK MEASUREMENTS

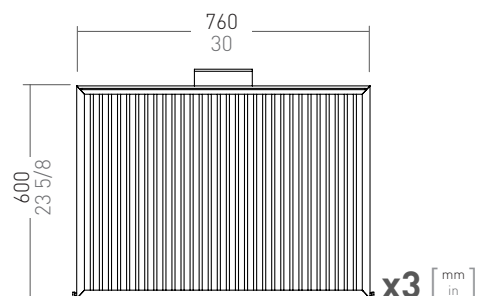

FT-C0077633-05



PVJ-76-3-3-MB

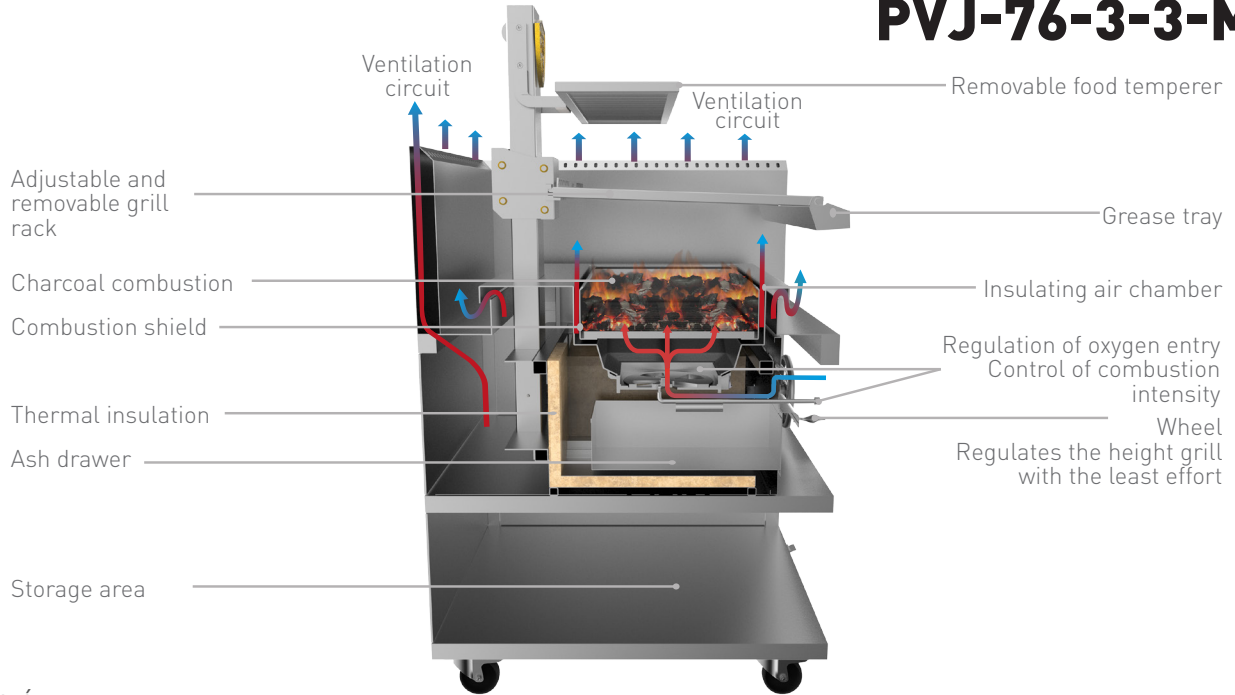

INSTALACIÓN
INSTALLATION

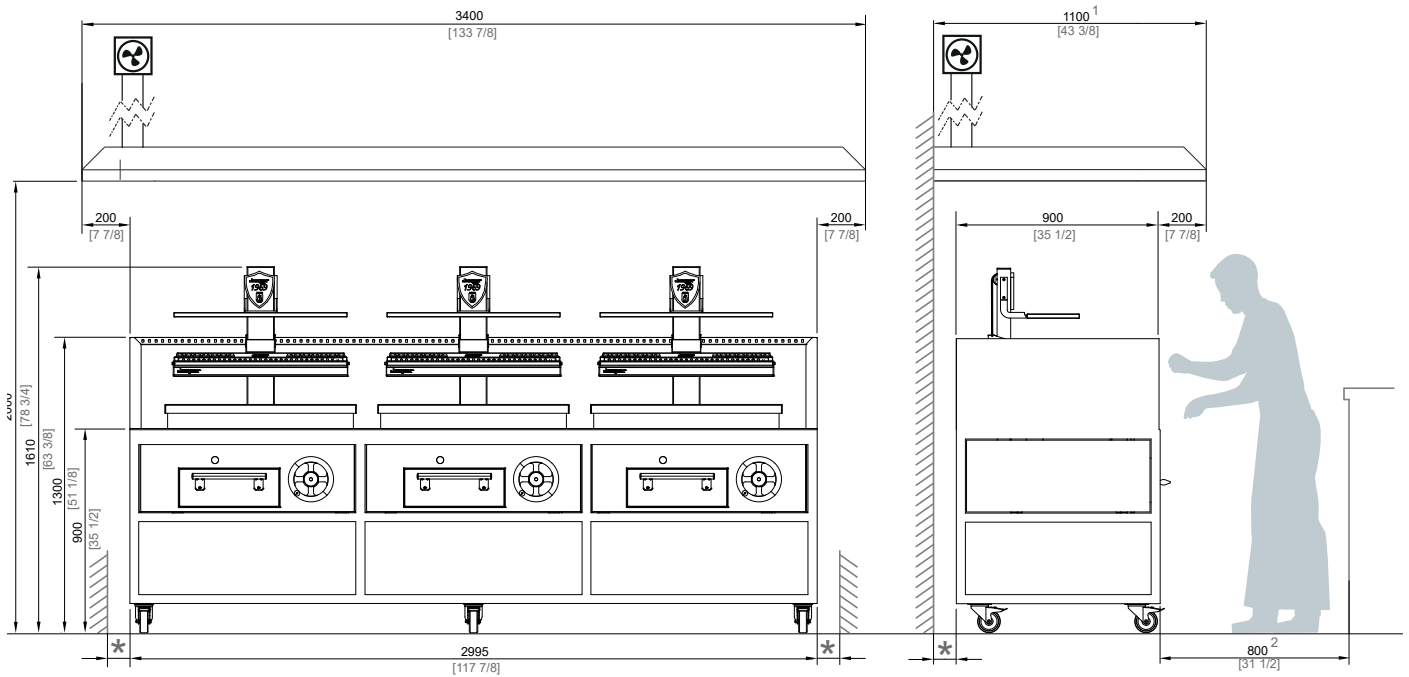

* DISTANCIA MÍNIMA A ELEMENTOS INFLAMABLES MINIMUM DISTANCE TO FLAMMABLE ELEMENTS	300 mm	12 in
* DISTANCIA MÍNIMA A ELEMENTOS NO INFLAMABLES MINIMUM DISTANCE TO FLAMMABLES ELEMENTS	100 mm	4 in

- 1 MEDIDAS MÍNIMAS RECOMENDADAS DE LA CAMPANA EXTRACTORA.
RECOMMENDED HOOD'S MINIMUM DIMENSIONS
- 2 ESPACIO RECOMENDADO DE TRABAJO PARA EL CHEF.
RECOMMENDED CHEF'S WORKING SPACE

Ed. 07.2022 - Jospser se reserva el derecho a realizar modificaciones en los catálogos, tarifas y material de divulgación según evolución y mejora de sus equipos.
 Jospser reserves the right to make modifications to catalogues, pricelists and promotional material according to the development and improvements applied to its equipment.